

# HABITAT FORMS™



## ENGINEERED HABITAT SYSTEMS

The Habitat family— Crabibat™, FishHouse™ and CoralForm™— offers durable, nature-positive structures that boost biodiversity, provide refuge for marine life and install easily with lighter equipment while outperforming traditional rock in ecological value and efficiency.

### CRABITAT™

Create refuge for benthic life.

#### KEY APPLICATIONS

- Building an intertidal-friendly refuge for crabs and juvenile species
- Living shoreline projects and coastal restoration
- Artificial reefs and fisheries enhancement zones
- Ecological features on breakwaters, jetties and seawalls
- Stabilization of banks and long-term shoreline resilience

#### KEY BENEFITS

- High-performance geometry design creates, enhances and protects coastal ecosystems
- Horizontal features specifically suit crabs, juvenile species and benthic life
- Optimized surface area promotes marine growth and ecological colonization
- Lightweight-for-volume construction improves installation efficiency
- Low environmental disturbance and reduced bottom impact
- Naturalistic forms blend seamlessly with the surrounding intertidal environments
- Engineered void spaces provide critical refuge for crustaceans and small organisms

#### INSTALLATION

Crabibat™ structures offer straightforward implementation and efficient deployment, requiring significantly lighter equipment for installation than traditional rock.

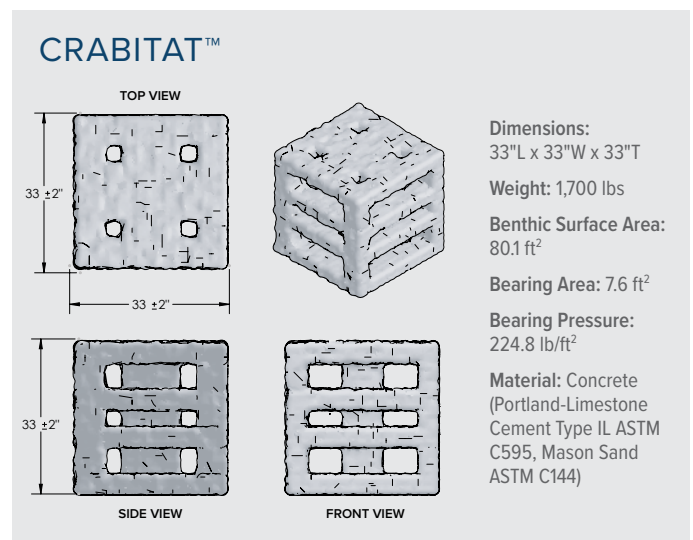

## FISHHOUSE™

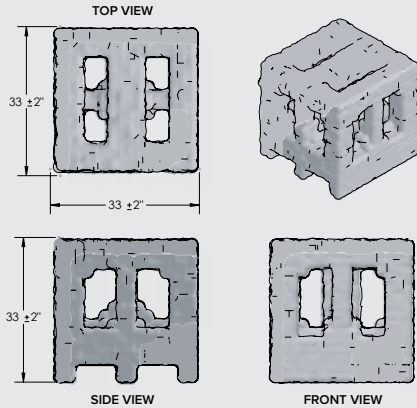

**Dimensions:**  
33"L x 33"W x 33"T

**Weight:** 1,500 lbs

**Benthic Surface Area:**  
67.2 ft<sup>2</sup>

**Bearing Area:** 7.6 ft<sup>2</sup>

**Bearing Pressure:**  
198.3 lb/ft<sup>2</sup>

**Material:** Concrete  
(Portland-Limestone  
Cement Type IL ASTM  
C595, Mason Sand  
ASTM C144)

## CORALFORM™

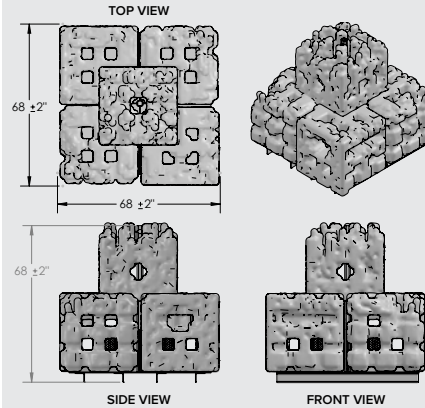

**Dimensions:** 68"L x 68"W x 68"T

**Weight:** ~10,000 lbs

**Benthic Surface Area:** 343.1 ft<sup>2</sup>

**Bearing Area:** 32.1 LB/ft<sup>2</sup>

**Bearing Pressure:** 311.4 lb/ft<sup>2</sup>

**Material:** Concrete (Portland-Limestone Cement Type IL, ASTM C595; Mason Sand, ASTM C144); internal structural steel hardware (ASTM A500 and ASTM A36) fully encapsulated within protective concrete coatings for corrosion resistance and long-term durability in marine environments.

## FISHHOUSE™

Provide vital marine refuge.

### KEY APPLICATIONS

- Living shorelines, fisheries and artificial reefs
- Medium wave energy and larger tidal fluctuation environments
- Great habitat for fish and small organisms
- Ecological feature on breakwaters, jetties and seawalls
- Projects desiring habitat complexity and biodiversity

### KEY BENEFITS

- Large surface area for less weight and material
- Organic shape and void spaces promote marine growth and provide ideal fish habitat
- Safer, faster and more cost-efficient installation compared with traditional methods
- Dramatically less material required than traditional rock-based solutions
- Expansive structural refuge for fish and small organisms
- Low environmental disturbance and reduced bottom impact
- Naturalistic forms blend seamlessly with surrounding environments
- Designed to boost biodiversity and ecological complexity

### INSTALLATION

Transport FishHouse structures to the project site and place them in the water with a small crane or excavator.

*Proudly Manufactured in Louisiana, USA*

## CORALFORM™

Support coral and marine habitat while maintaining structural stability in high-energy environments with this modular 3D-printed concrete reef system. Built using Natrx's ExoForm™ technology, CoralForm combines advanced digital design with DryForming™ concrete production to achieve high rugosity, complex geometry and long-term durability.

### KEY APPLICATIONS

- Offshore coral reef restoration
- Artificial reef development
- Fisheries enhancement projects

### ECOLOGICAL FEATURES

- High rugosity and surface complexity for enhanced biological attachment
- Varied hole sizes, crevasses, ledges, spires and overhangs
- Integrated coral attachment points for diver-assisted installations
- Habitat support for corals, fish, and reef invertebrates

### SYSTEM CONFIGURATION & STRUCTURAL PERFORMANCE

To create vertical relief and habitat complexity, each CoralForm module consists of five interlocking units – four base units support a fifth top unit.

- Engineered for stability in high-energy storm events
- Withstands wave heights exceeding 18 feet with 18-second wave periods in depths of over 30 feet
- Designed for various simplified rigging and lifting operations

For more information regarding Shoreline Protection, contact your local expert at [info@ferguson.com](mailto:info@ferguson.com) or visit us at [fergusonwaterworks.com](http://fergusonwaterworks.com).